

ADVANCE BEACH HOUSE RESERVATION

Name: _____

Apartment #: _____

Telephone: _____

Desired Date: _____

Desired Time: _____

Total Guests: _____

Tables Needed: _____

Grills Needed: _____

Bar Needed: _____

Request Received by/Date: _____

APPROVED BY/DATE: _____

Called back by/Date: _____

NEED GUEST LIST: YES NO

TABLES 2 THRU 9 -- OUTDOORS
TABLES 10 THRU 15 -- UNDER ROOF
TABLES 8 & 9 -- NOT TO BE RESERVED
GRILL 1 -- NOT TO BE RESERVED

MAXIMUM 3 TABLES & 2 GRILLS
MORE MUST BE APPROVED BY OFFICE

BEACH HOUSE PHONE: 954-941-3962

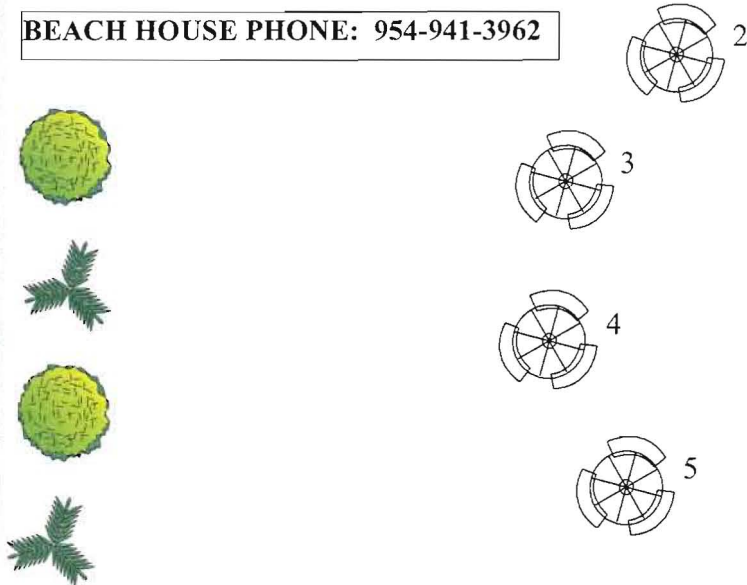
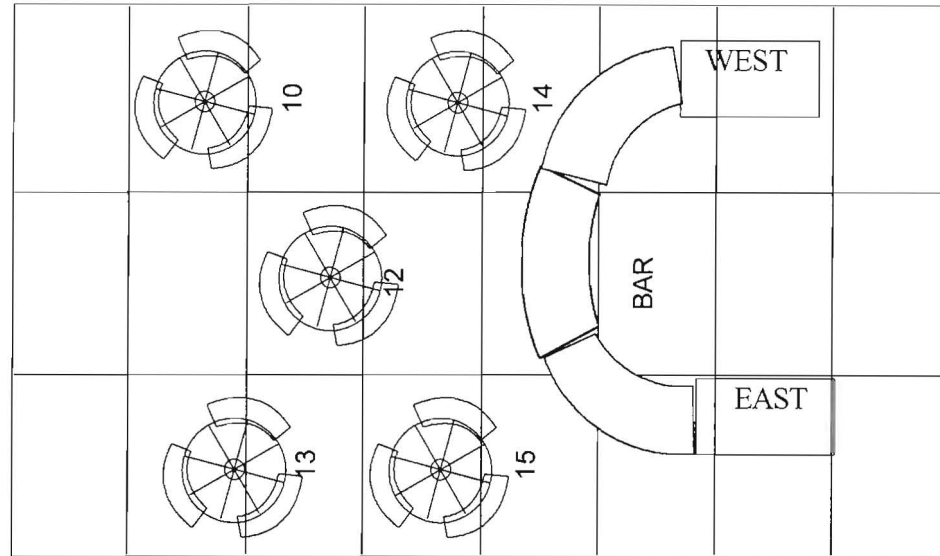

GAS GRILLS



PICNIC TABLES



CHARCOAL GRILLS

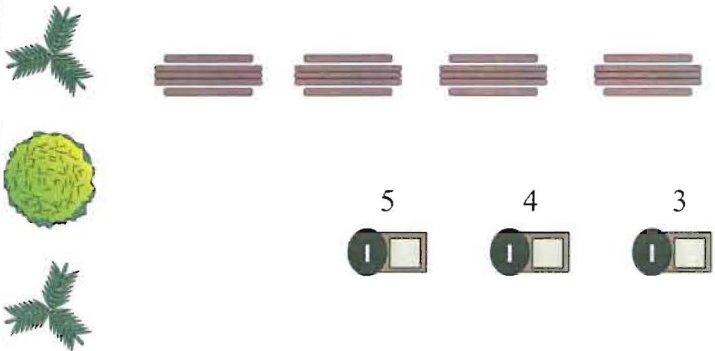

PLEASE MARK SELECTED TABLES AND GRILLS

Sea Ranch Club Condominium Association, Inc.

Rules for Use of Tables and Grills At All Beach Houses

As approved by the Board of Directors, Sea Ranch Club Condominium Association, Inc.

1. Regular reservations may be made through the Security Desk of each Building no more than 48 hours prior to use. Three Beach House tables and one charcoal grill can be reserved. Special reservations for more tables and grills must be approved by the Manager and can be made 30 days prior to use. Reservations must include the number of persons in the party. The number of guests cannot exceed 60 non-resident visitors. A guest list must be provided no less than one week in advance; otherwise, the Association may deny access to visitors, guests, or invitees without advance identification. Reservations must be made individually. Gas grills cannot be reserved.
2. One-half of the bar can be reserved, if needed.
3. Reservation notices will be posted by Security Officers on each reserved table, grill, or bar side. Notices will be posted 1½ hours prior to reserved time. Reserved areas must be vacated by others. If a reservation has not been kept by 1 hour past the reserved time, Security Officers must be notified so that the notice can be removed and the facilities made available to other residents.
4. Children should be under direct adult supervision at all times.
5. Beach House tables 8 and 9 cannot be reserved; they must be available at all times for other residents who will have free access to the refrigerator, freezer, ice machine, microwave, and sink. There should be no interference with private party activities.
6. Buildings “A”, “B”, and “C” and the Association shall have priority rights to all facilities, including Tables 8 and 9, for parties.
7. Reservations for lunch will extend to 4:00 p.m. Reservations for dinner will extend from 5:00 p.m. to closing. Exceptions to these times may be approved by the Manager.
8. Noise (radios, musical instruments, etc.) will be minimized after 10:00 p.m. in Association areas.
9. No person under legal drinking age (21 years) may consume any alcoholic beverages on this property. ID cards should be carried and shown upon request.
10. Beach House tables cannot be used for storage or for serving.
11. Beach House tables cannot be moved from terraces to interiors.
12. Ice machines cannot be used for storage of food or beverages.
13. The person making the reservation is responsible for thorough clean-up of Beach House facilities after each use. Trash containers and bags will be made available by the staff to assist with clean-up.
14. Owners are responsible for actions of their family members, guests, lessees, licensees, and invitees.
15. During holidays (e.g., New Year’s Eve, New Year’s Day, Easter, Memorial Day, Independence Day, Labor Day, Thanksgiving Day, Christmas Eve, and Christmas Day) and on special occasions (e.g., Air and Sea Show, Mother’s Day, and Father’s Day) only one table per reservation will be approved 30 days in advance.
16. No smoking in pool areas, in beach houses (cabanas), or on paved areas (pavers) 25-ft. around beach houses (cabanas) and pool areas of Buildings “A”, “B” and “C”.
17. Picnic tables and grills on the sand may be reserved on a first-come first-serve basis.